

# e-IXP Centrifugal Pump designed according to ISO 2858 and ISO 5199

STANDARDIZATION MATCHES INNOVATION

# Standardization matches innovation.

e-IXP is the new innovative Xylem Industrial Pump designed according to ISO 2858 and 5199 to be *THE SOLUTION* to industrial applications. The new e-IXP pump is able to meet the pumping needs of customers in virtually all major markets and can be supplied in multiple construction materials, with various shaft sealing configurations. Derived from customer input and extensive Xylem experience, the design objective was

to create a reliable and efficient pump with reduced lifecycle cost.

Thanks to our new *Xylem optimize technology*, health of the pump will be always under control.

The new e-IXP is a single stage volute casing end suction pump, available in different constructions thanks to a true modular design.

- 1 ENHANCE YOUR INDUSTRIAL CAPABILITY.**
  - Range extension up to DN 250 increases the flow by 65% compared to the previous range.
  - Large choice of casing and impeller material combinations, both PN16 and PN25, to solve different needs in the industrial market.
  - Wide range of bearing bracket arrangements and sealing options available as well as API plans on request.
  - Optional inducer reduces NPSH value up to 50% and allows the pump to work with fluids with up to 25% entrained air.
- 2 STREAMLINE YOUR INVESTMENT.**
  - Standardization according to ISO 2858 and ISO 5199 simplifies integration in existing systems.
  - Modular design optimizes spare parts management and reduces lead time.
  - Stub shaft with compact construction reduces the footprint by up to 35%; a cost-effective solution for applications with space constraints.
- 3 REDUCE YOUR ENERGY COST.**
  - Efficiency up to 10% higher compared with the previous ISO range thanks to optimized hydraulics.
  - Use of Hydrovar or Aquavar to optimize performance: proved 50% energy saving using variable speed with a 11kW pump.
  - Standard wear rings and dry shaft in stainless steel with Duplex sleeve ensure a longer life and reduce downtime.

## Range overview.

Sizes: DN25 - DN250  
Power: 0,55 kW- 200 kW  
Heads up to: 160 m  
Flows up to: 1270 m<sup>3</sup>/h

## Main features.

Liquid temperature: -40 ÷ 180°C  
Design pressure: Max 25 bar  
Standard flanges: EN1092/  
ISO7005, PN16 and PN25  
Optional flanges: ASME B16.5  
compatible with Class 150 and  
300 drilled

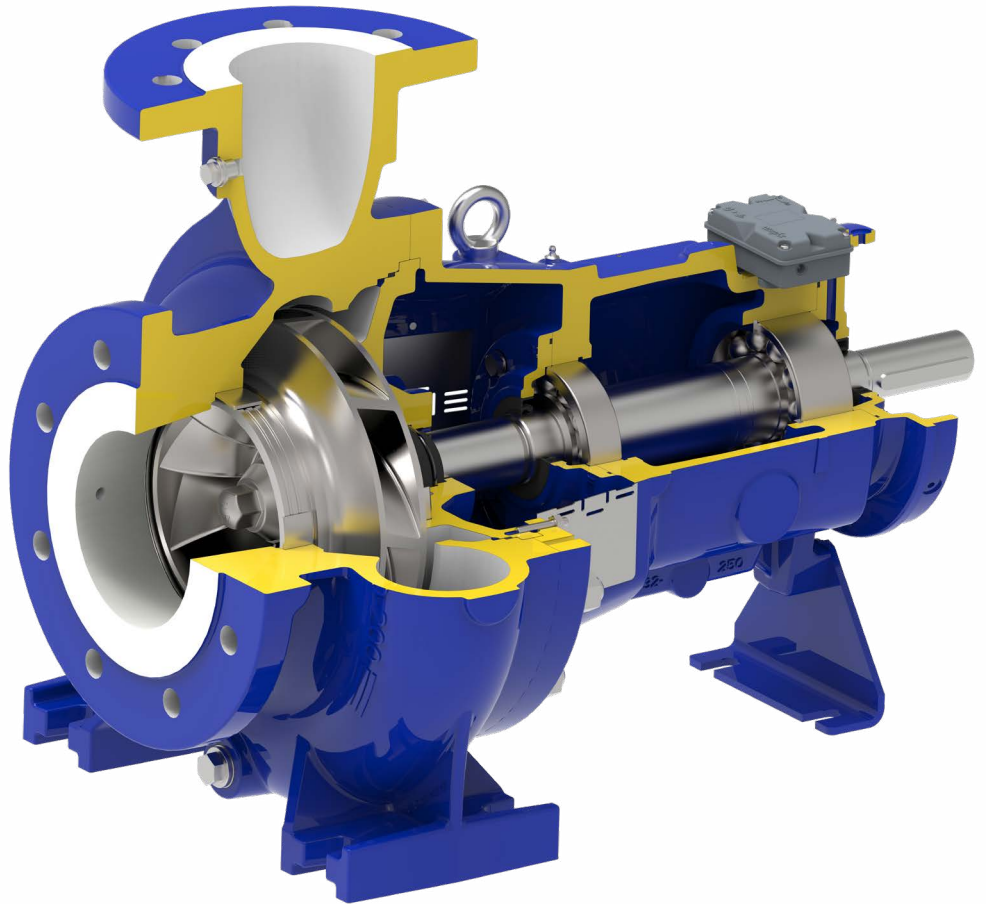

## 4 SECURE YOUR PROCESS WITH OPTIMIZE.

Prevent pump breakdowns and avoid expensive downtime with predictive maintenance advice.

Easily generate reports to simplify documentation, manage your system and spares and inform purchasing.

Monitor system health on a simple-to-use App and automatically share your data with other local users.

## 5 IMPROVE MAINTENANCE.

Heavy duty bearing bracket with large capacity oil sump lowers temperature and grants L10 bearing life up to 40.000 hrs decreasing your service needs.

Patented cyclone seal chamber increases mechanical seal life up to 5 times when processing fluids with abrasive elements.

Back pull-out design, machined baseplate and jack screws make commissioning and maintenance easier and safer.

# The first ISO pump with remote monitoring & control.

## **Xylem optimize.**

optimize is a modular condition monitoring solution that provides health guidance and predictive maintenance advice for rotating and fixed assets such as pumps, motors, heat exchanges and steam traps.



By periodically monitoring vibration, temperature and magnetic flux, optimize is able to identify potential problems with your equipment before they occur. Health information is collected, stored and analyzed in the optimize sensor before being wirelessly transmitted to your iOS or Android smart device via Bluetooth. The optimize mobile application provides an easy interface to understand the health of your assets, create maintenance reminders and generate detailed reports.

The optimize sensor is powered by a replaceable 3.6V Lithium Thionyl Chloride battery pack that will enable the sensor to operate for 3 to 5 years. The sensor is designed for indoor or outdoor mounting using the supplied magnetic feet or the optional fixed bracket.

## **Variable Speed Options.**

### **5<sup>th</sup> Generation Hydrovar Intelligent Control System.**

Accurately adapts to system demands and helps end-users to reduce costs and save energy while achieving optimum system performance. Motor or wall mounted options, with power from 1,1 to 22 kW.



### **Aquavar IPC.**

Aquavar IPC is an Intelligent Pump Controller, designed for precise control of speed, pressure, flow and level over a wide range of submersible and surface applications. Wall mounted, with power up to 90 kW.



# More options to suit even more applications.



## ...as well as

- Public utilities
- Water distribution
- Irrigation
- District heating and cooling
- Desalination plants

# Different construction for different needs.

## e-IXPC

Frame mounted single-stage volute casing end suction pump. The hydraulics are coupled to the motor using a spacer coupling. **When you need a more robust and versatile version.**

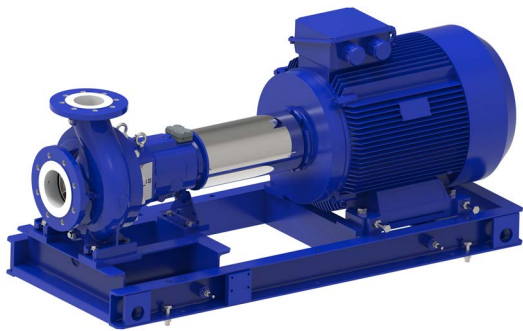

## e-IXPS

Single-stage horizontal volute casing block pump, rigidly coupled to a standard motor. **When you need a more compact and economic solution.**



## e-IXP

Single-stage horizontal bare shaft pump, to be coupled to any standard IEC motor. **When you need to substitute an existing ISO 2858 pump.**



## Performance Range.

The e-IXP pump offers a broad hydraulic range: it delivers up to 1270 m<sup>3</sup>/h and 160m max head with motor power up to 200 kW.

More sizes equals more opportunities to optimize efficiency for your application. Whether your system requires small or large capacity, we have the right pump for you.

### Performance, 2-pole, 50Hz

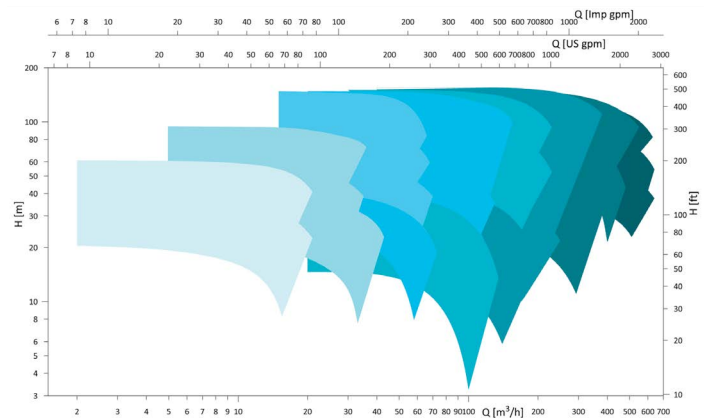

### Performance, 4-pole, 50Hz

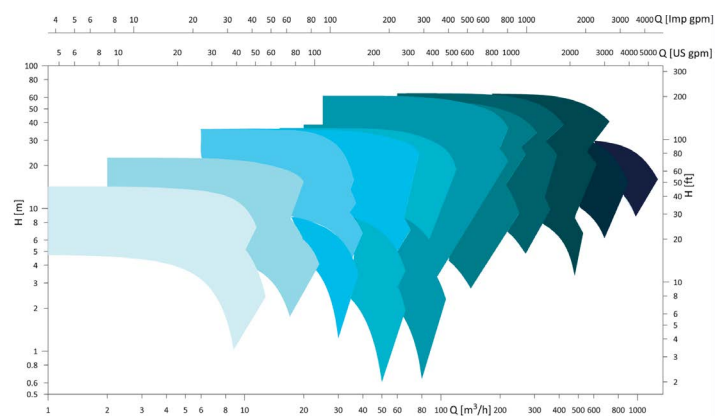

### Performance, 6-pole, 50Hz

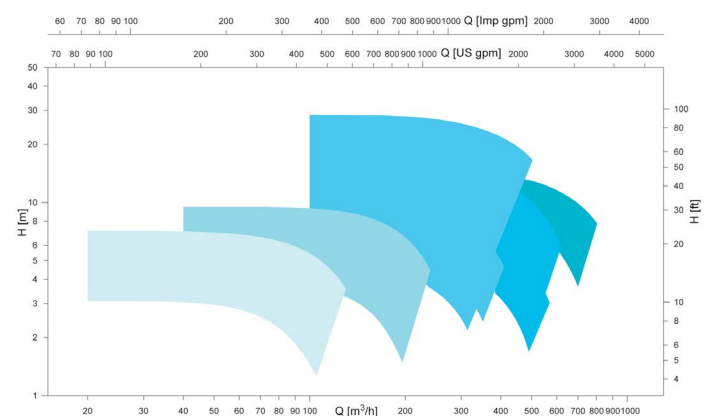

## Accessories.

A long list of accessories is available:

Anchor bolts and epoxy capsule anchor bolts

Drip pan in stainless steel

Casing drain with flange

API Plans

Inducer\*

Different sensors

\*not for all sizes

## Product Certificates.

Standard test report according to ISO 9906

- Class 2B as standard  
- Class 1B, 1U on customer request

Vibration test report

Bearing temperature rise

Material certificate according to EN 10204-2.2 and -3.1 (for all wet and pressurized components)

Traceability of components

## Features.

### Casing

Designed for 25 bar in Ductile Iron and Duplex, 16 bar in AISI 316, Super Duplex and Super Austenitic on request. The casing has a centerline discharge which minimizes piping stress.

### Flange drilling

The flanges are drilled to EN1092/ISO7005, PN16. To enhance versatility we can deliver PN25 drilled flanges and ASME B16.5 compatible drilled flanges, Class 150 and 300.

### Wear ring

Duplex casing wear rings are offered as standard on all pumps, which prevents wear of the casing and casing cover, lowering the maintenance costs. Super Duplex or Super Austenitic on request. Impeller wear rings on request.

### Bearing bracket

Double row drive-end ball bearing regreasable (25.000 hrs) or oil lubricated (sealed by labyrinth - 40.000 hrs).

### Shaft

Dry shaft in AISI 431 with shaft sleeve in Duplex. Duplex shaft and Super Duplex or Super Austenitic sleeve on request.

### Seal and seal chamber

Cyclone seal chamber to allow particle removal. Standard single unbalanced mechanical seal. Optional balanced mechanical seal, single cartridge, double cartridge, packing.

### Impeller

Optimized hydraulics to guarantee high efficiency and wide hydraulic coverage. Impellers are available in AISI 316 and Duplex, Super Duplex and Super Austenitic on request.

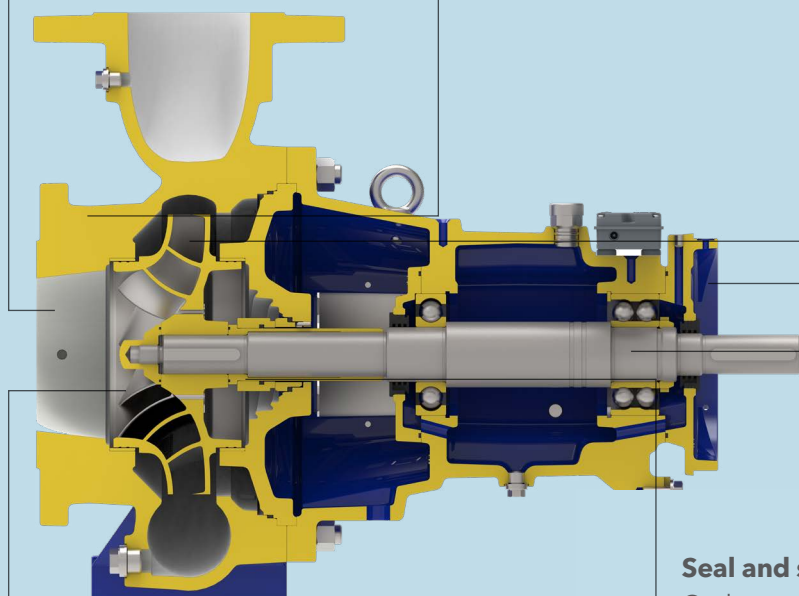

# Xylem ['zīləm]

- 1) The tissue in plants that brings water upward from the roots
- 2) A leading global water technology company

We're 12,000 people unified in a common purpose: creating innovative solutions to meet our world's water needs. Developing new technologies that will improve the way water is used, conserved, and re-used in the future is central to our work. We move, treat, analyze, and return water to the environment, and we help people use water efficiently, in their homes, buildings, factories and farms. In more than 150 countries, we have strong, long-standing relationships with customers who know us for our powerful combination of leading product brands and applications expertise, backed by a legacy of innovation.

For more information on how Xylem can help you, go to [xyleminc.com](http://xyleminc.com)



We offer:

- Engineering and technical solutions of Xylem for water supply, wastewater and water purification systems, which are leading in the world.
- A full range of pumps and equipment for such applications as supplying drinking or untreated water, diversion of industrial wastewater, sewage, drainage, monitoring installations and operation, primary and secondary biological treatment, filtration and disinfection.
- Technical support and maintenance of pumps. Our local service center provides comprehensive services and support for safe, efficient and reliable operation. You can rely on us to ensure trouble-free operation and minimal downtime. We will quickly respond and give a professional answer to your questions, as well as provide high-quality service using original spare parts.

## **Free Line Group LLC**

*Official distributor and service-partner of Xylem Inc.  
in Uzbekistan, Tajikistan, Kyrgyzstan and  
Turkmenistan*

Tel: +998 95 475-00-40  
+998 90 350-38-68  
+998 90 908-97-11

Makhtumkuli str. 105, Yashnabad distr.,  
Business-center "ERA", Tashkent, Uzbekistan

email: [info@flgroup.uz](mailto:info@flgroup.uz)  
Web: [www.flgroup.uz](http://www.flgroup.uz)